

## Description

RKBI is an insulated centrifugal duct fan with connections for rectangular ducts. The fan have a rigid housing of galvanised steel and are compact with high capacity. With the 50 mm high quality insulation it operates quiet and the surface of the insulation is easy to clean. RKBI is available in 16 capacities. The backward curved impeller gives a better efficiency over a very big working area than the forward curved impeller. The fan is designed to cope with high pressures i.e. long ducts with a minimum of noise. The motor is speed-controllable from 0-100% and maintenance-free, why the only service required is cleaning the impeller. Motor with impeller can be swung out for inspection and cleaning (swing-out). The RKBI fan is supplied fully-wired and ready to fit in a sealed installation unit. It is moisture-proof and approved for use in warm or cold environments. All fans are fitted with a built-in thermal protector.



## Technical data

Parameter	Value	Unit
Voltage	400	V
Phase	3	~
Frequency	50	Hz
Power	2.46	kW
Current	4.9	A
R.p.m.	22	r/s
Max. temperature of transported air	50	°C
Max. temperature of transported air when speed-controlled	50	°C
Sound pressure level at 3 m	58	dB(A)
Length	1047	mm
Width	1105	mm
Height	649	mm
Weight	124	kg
Enclosure class, motor	44	IP
Insulation class, motor	F	
Duct connection	1000x500 mm	

Diagrams

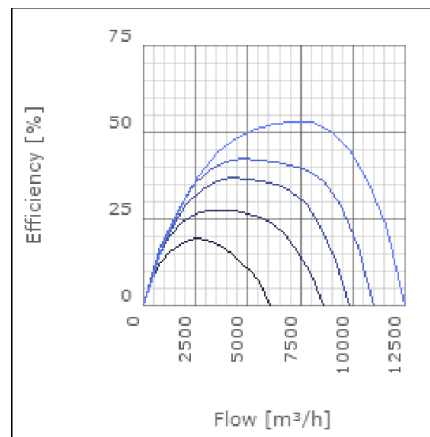
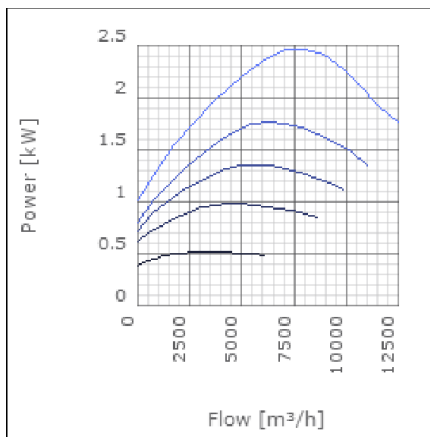
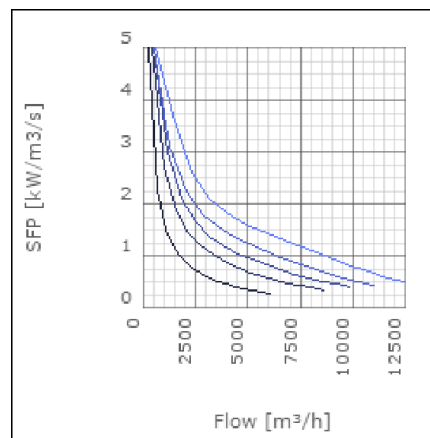
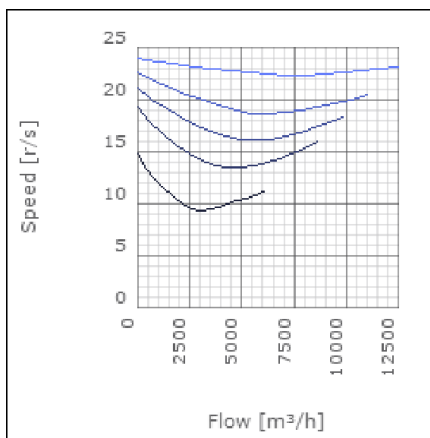
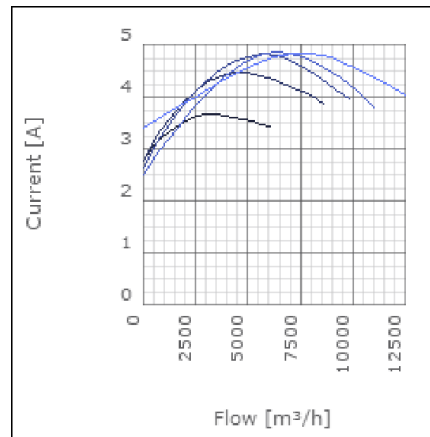
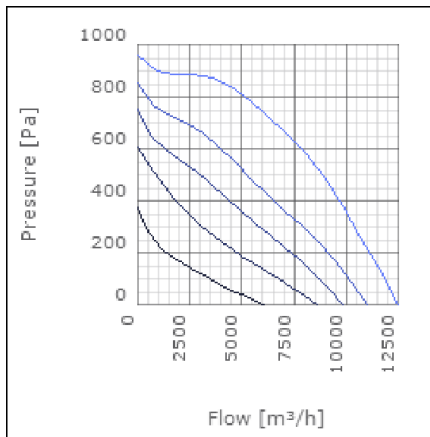

Sound

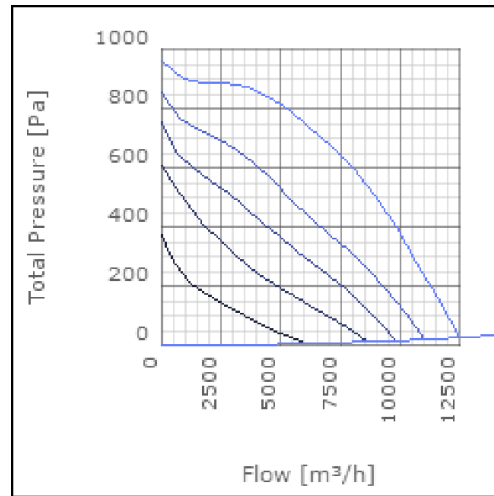
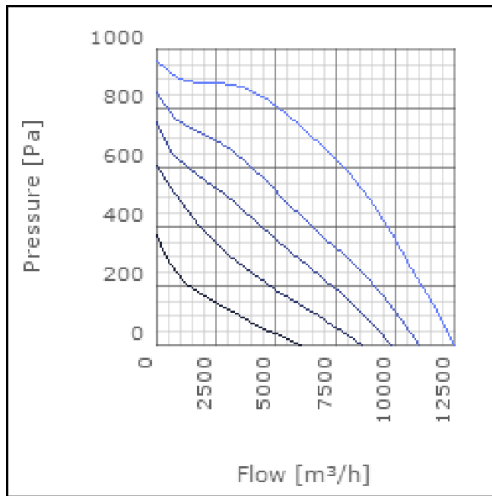

	Tot	63	125	250	500	1k	2k	4k	8k
Inlet	-	-	-	-	-	-	-	-	-
Outlet	-	-	-	-	-	-	-	-	-
Surrounding	-	-	-	-	-	-	-	-	-
Surrounding	-	-	-	-	-	-	-	-	-

  

120									
80									
40									
0									
	Tot	63	125	250	500	1k	2k	4k	8k

**Parameter**

Distance: 3.000  
 Propagation type: Hemi-spherical  
 Equivalent absorption area: 20.00

## Dimensions

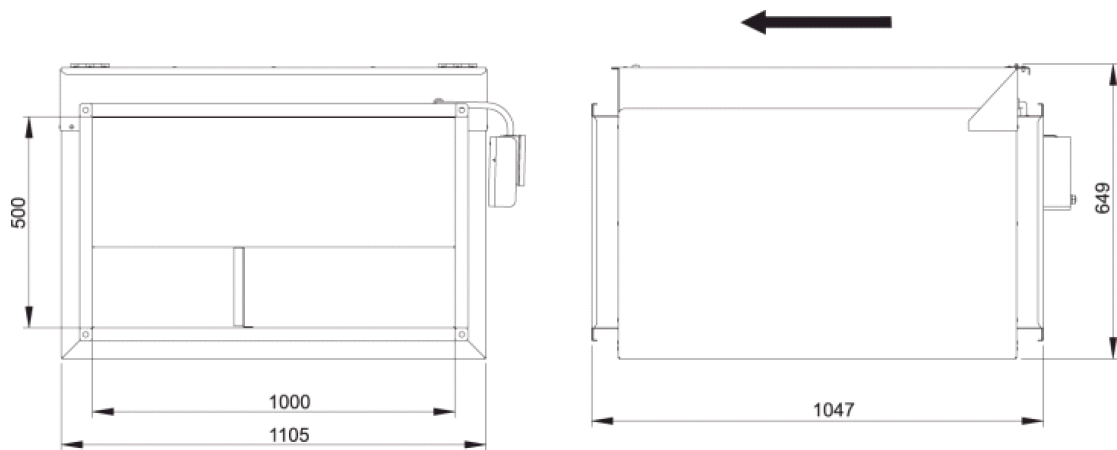

## Wiring diagram

4040004

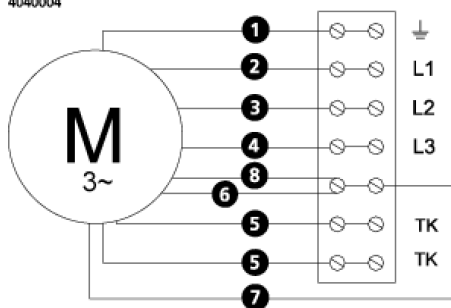

- (M) = Fan Motor
- (M1) = Fan Motor
- (M2) = Fan Motor
- (M3) = Rotor Motor
- 1 = Yellow/Green
- 2 = Black
- 3 = Blue
- 4 = Brown
- 5 = White (TW)
- 6 = Orange
- 7 = Grey
- 8 = Red
- 9 = Green
- 10 = Violet

## Accessories

VRDT 7  
VRTT 7

## Electrical accessories

FLR 1000x500  
DS 1000x500  
LDR 1000x500